

## Sketch of the Ka'bah and Sections Related to the Hajji

Sketch of the Ka'bah and Sections Related to the Hājjī

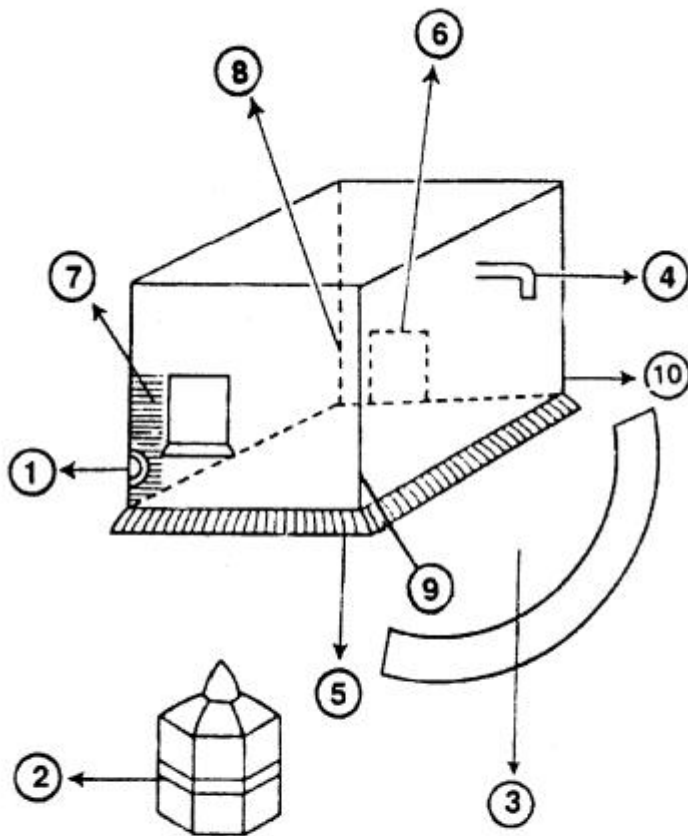

- |                     |                       |
|---------------------|-----------------------|
| [1] Hajar al-Aswad  | [6] Mustajar          |
| [2] Maqām Ibrāhīm   | [7] Hatwim            |
| [3] Hijr Ismā'il    | [8] Al-Rukn al-Aimāni |
| [4] Mizāb al-Rahmah | [9] Al-Rukn al-Iraqi  |
| [5] Shadharwan      | [10] Al-Rukn al-Shāmi |

# 1. The Black Stone

Start and finish your Tawaf at the Black Stone. The Holy Prophet says that he who does Tawaf of the House at noon with his head bare, bare-foot, making his steps short, closing his eyes (overlooking, disregarding others) and touching the Black Stone in every round he makes, without hurting anyone nor cutting short his praise and glorifying of Allah, will be rewarded for each step he makes with seventy thousand good deeds. Seventy thousand of his evils will be wiped off; his rank will be increased by seventy thousand grades; he will be given the reward as if seventy thousand slaves, each whose price is ten thousand dirhams were freed on his behalf; seventy of his family members would be cured of any sickness, and seventy thousand of his needs would be granted –sooner or later.

The Holy Prophet (s) said: *“Touch the corner (in which the Black Stone rests) for it is the right hand of Allah amongst his creation with which he greets His servants a greeting of a slave (or man). It will be witness to the loyal. “*

It is recommended to kiss it, if not possible touch it; and if not possible then to point at it (make a gesture).

# 2. Maqam Ibrahim

Allah says: *“Appoint for yourselves a place for prayer on the standing place of Ibrahim. “* It is enough to note that the preference of this place is symbolized by bearing the name of this great Prophet. His rank is one of the most perfect due to the fact that he spent the whole of his life, his family's and the whole of his wealth for the sake of Tawhid and keeping firm Allah's signs by building the Ka'bah at the centre of His House.

# 3. Hijr Isma'il

This is his (Isma'il's) house. He and his mother were buried in there. Halabi narrates from Imam as-Sadiq (as) saying: *“ I asked him concerning Hijr Isma'il and said: You call it the smashed (smasher) but it was for Isma'il's sheep (and goats). His mother was buried in there and denied access to anyone, for he did not like it to be walked on. “* Other Prophets are buried in this place also.

Imam al-Baqir (as) said: *“The place (around) between the Rukn (corner) and the Maqam is full of graves of Prophets”* Imam Sadiq (as) says that seventy prophets were buried between Rukn al Amani and Hajar al-Aswad. As such, when at this place, you should perform the Ziyarat of Isma'il , his mother and the prophets

It is recommended to put on Ihram of Hajj at-Tamattu` at the Hijr facing Mizab al-Rahmah which is a place of supplication and asking for Allah's Mercy.

## 4. Mizab ar-Rahmah

It is recommended to face the Mizab and supplicate as narrated by `Ayyub from Imam Musa ibn Ja'far (as) which can be found in the various books of supplication related to the Hajj.

## 5. Shadharwan

This is the remaining part at the foundation of the House's wall.

## 6. Mustajar

The place which is opposite the Ka'bah is called Mustajar, Mutawwadh or Multazam. There are many traditions in preference of the place. Imam 'Ali (as) says: "Confess in recognition of the sins you recall at Multazam."

It is narrated that he who does this and repents for all his sins, Allah will definitely forgive him. In one of the books, it is said that at Multazam, Imam Sadiq (as) used to tell his companions to give him time that he could confess and disclose his "sins" to his Lord saying that the place was of a very high spiritual preference.

In another tradition it is said that when Prophet Adam (as) was at this place, the Angel Jibra'il told him to disclose his "sins" to the Lord. Prophet Adam (as) did so and his "sins" were forgiven. Prophet Adam (as) then asked Him to forgive his son(s) (or his descendants) for their sins. Allah answered back saying that He could only forgive those who went and repented at that spot.

It is recommended for one in his seventh round or after Tawaf to spread out his hands, touch, and let his body and cheek touch the House and recite the supplications that Imam Sadiq (as) used to recite in this place.

## 7. Hatwim

This is the place between the door of the Holy Ka'bah and Hajar al-Aswad. It is one of the holy places and it is upon one to ask for forgiveness at this place. He should pray, supplicate and cling to the curtains of the Ka'bah for at this place, great and major sins are completely destroyed and smashed. This is the reason of calling the place by this name *smasher*. In other traditions it is said that it is the place where Adam (as) was forgiven of his sins.

## 8. Al-Rukn al-Aimani

The place opposite the Black stone behind the House is the one is called al-Rukn al-Aimani (the right-hand side corner). There are many traditions that have been narrated in preference of this place to

an extent that perplexes and boggles the mind. The Holy Prophet said: *“Whenever I come to at this point I find that Jibra'il is already there before me. “*

Imam Ja'far (as) said: *“The Rukn al-Aimana is our gate to paradise. “*

He also said: *“In this place, is one of the doors of paradise that has never been closed since it was opened. There is a river from paradise in which deeds of the servants are dropped. “ He continued by saying: “There is an angel who has been stationed at this point since the creation of the heavens and the earth whose duty is nothing other than to take care of your supplications. As such one must be careful with what he is saying. One should make use of his presence at this holy place as Possible and should not waste time doing things that are of less importance.”*

## **9. Al-Rukn al-Iraf**

This corner is named as such since it faces towards Iraq – south east.

## **10. Al-Rukn al-Shamh**

It is recommended to touch all the corners according to the narration from Jamil bin Salih that he saw Imam Sadiq (as) touching them all.

All the same, it is stressed to touch Rukn al-Aimani and the corner where the Black Stone rests. It is understood from traditions that the Holy Prophet; used to touch them all. Of course, all this depends on the fact that you don't disturb other people around you otherwise the recommended act loses authenticity and if anything it could even be haram (forbidden).

The Rukn al-Sharqi (Eastern Corner) is where the Black stone rests while Rukn ash-Shimali (Northern Corner) is the one which comes after the Holy Ka'bah's door before reaching Hijr Isma'il. It is well known as Rukn al-Iraqi (it is also called Rukn ash-Shami).

Rukn al-Gharbi (Western Corner) is the one that comes after Hijr Isma'il (also called Rukn ash-Shami). Rukn al-Junubi (Southern Corner) is the one that comes before the Black Stone corner (also known as Rukn al-Aimani).

---

### **Source URL:**

<https://www.al-islam.org/secrets-hajj-ayatullah-husayn-mazaheri/sketch-ka%E2%80%99bah-and-sect ions-related-hajji>